

# WIEGAND-IF2 INSTRUCTIONS (ELITE S SYSTEM)

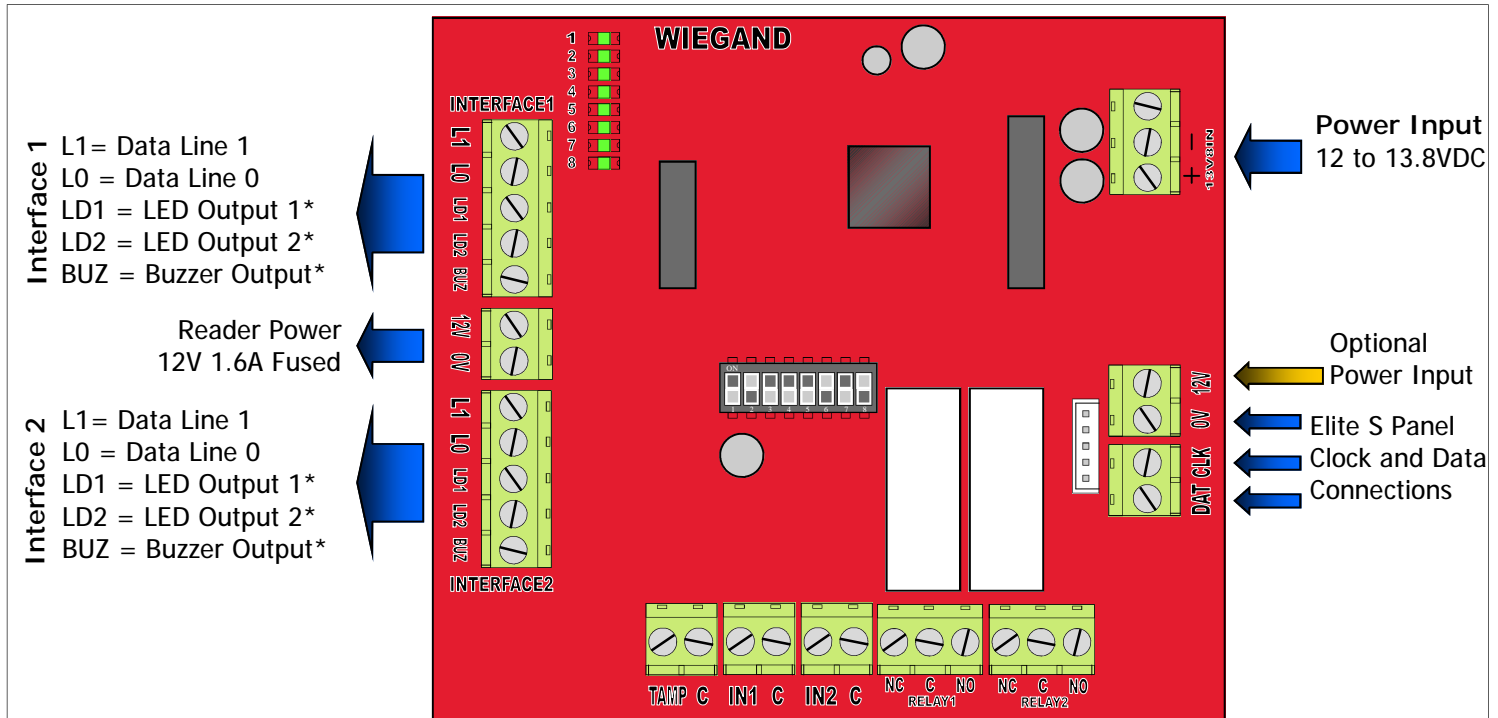

LED	Function
1	Input 1 Unsealed
2	Interface 1, LED 1 Output
3	Interface 1, LED 2 Output
4	Interface 1, Buzzer Output
5	Input 2 Unsealed
6	Interface 2, LED 1 Output
7	Interface 2, LED 2 Output
8	Interface 2, Buzzer Output

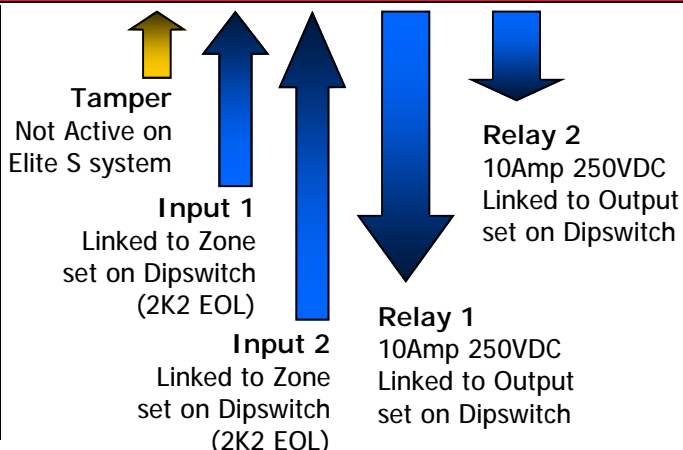

## INTERFACE CONNECTIONS:

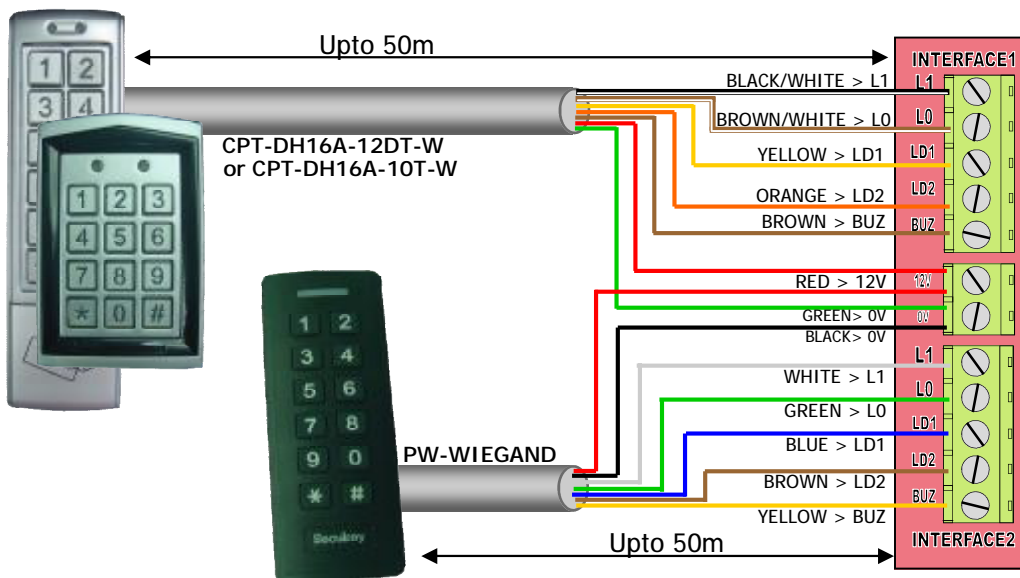

TERMINAL	FUNCTION
L1	DATA LINE 1 (D1)
L0	DATA LINE 0 (D0)
LD1	LED 1 (Programmable under address P98E of Elite-S Manual)
LD2	LED 2 (fixed to button response)
BUZ	BUZZER (programmable under keypad options of Elite-S Manual)
12V	+12VDC 1.6A Outlet
0V	-0VDC/Common Outlet

Interface-1 (Keypad Address 1-8 set on Dipswitch 1, 2 & 3 see pg2)  
 Compatible Readers: CPT-DH16A or PW-WIEGAND

Interface-2 (Keypad Address 2-8 set on Dipswitch 4, 5 & 6 see pg2)  
 Compatible Readers: CPT-DH16A or PW-WIEGAND

**NOTE:** # & \* = ENTER

On CPT Keypads both the \* & # are used as enter buttons.

# DIPSWITCH OPTIONS: (ELITE S ONLY) NOT FOR ELITE SX SYSTEM

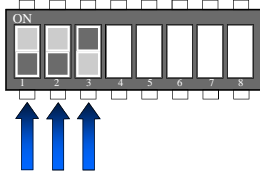

Interface 1 Can be set to Keypad Address 1 to 8 using Dipswitches 1, 2 & 3  
These Dipswitches also Link Relay 1 to an Output and Input 1 to a Keypad Zone.

Interface 1, Keypad Address Assignment					
IF-1	DIP 1	DIP 2	DIP 3	RELAY-1 Linked to	INPUT-1 Linked to
KP Address 1	OFF	OFF	OFF	Output 1	Zone 1 or 9
KP Address 2	ON	OFF	OFF	Output 2	Zone 2 or 10
KP Address 3	OFF	ON	OFF	Output 3	Zone 3 or 11
KP Address 4	ON	ON	OFF	Output 4	Zone 4 or 12
KP Address 5	OFF	OFF	ON	Output 5	Zone 5 or 13
KP Address 6	ON	OFF	ON	Output 6	Zone 6 or 14
KP Address 7	OFF	ON	ON	Output 7	Zone 7 or 15
KP Address 8	ON	ON	ON	Output 8	Zone 8 or 16

**Example:** If Dipswitches 1 & 2 are Off and 3 is On then the device wired to IF-1 will be on Keypad address 5.  
Also Relay-1 will follow Output 5 and Input-1 can be programmed to be either Zone 5 or 13 in the Elite S.

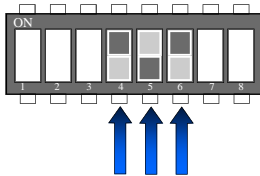

Interface 2 Can be set to Keypad Address 2 to 8 using Dipswitches 4, 5 & 6  
These Dipswitches also Link Relay 2 to an Output and Input 2 to a Keypad Zone.

Interface 2, Keypad Address Assignment					
IF-2	DIP 4	DIP 5	DIP 6	RELAY-2 Linked to	INPUT-2 Linked to
Disabled	OFF	OFF	OFF	None	None
KP Address 2	ON	OFF	OFF	Output 2	Zone 2 or 10
KP Address 3	OFF	ON	OFF	Output 3	Zone 3 or 11
KP Address 4	ON	ON	OFF	Output 4	Zone 4 or 12
KP Address 5	OFF	OFF	ON	Output 5	Zone 5 or 13
KP Address 6	ON	OFF	ON	Output 6	Zone 6 or 14
KP Address 7	OFF	ON	ON	Output 7	Zone 7 or 15
KP Address 8	ON	ON	ON	Output 8	Zone 8 or 16

**Example:** If Dipswitches 4 & 6 are On and 5 is Off then the device wired to IF-2 will be on Keypad address 6.  
Also Relay-2 will follow Output 6 and Input-2 can be programmed to be either Zone 6 or 14 in the Elite S.

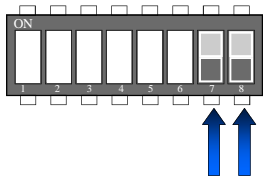

Choose the Interface Protocol to match your Wiegand devices

Interface Protocol		
	DIP 7	DIP 8
Competition	OFF	OFF
AC-2 Mode	ON	OFF
Spare	OFF	ON
Spare	ON	ON

Elite S Standard mode  
Turns # key into Prog function, (for use on AC-2)

## INPUTS & OUTPUTS:

To activate Input-1 and 2 you must first set the Dip switches (see tables above) this will give you 2 optional Zones to for each Input to choose from.  
Then you will need to program that zone to be a Keypad Zone, make it a Chime Zone and link it to an Output.  
Please follow the programming on pg5.

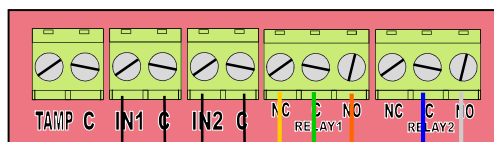

Both Relay-1 & 2 have clean volt free, normally open and normally closed contacts. The Relays are linked to outputs on the panel using the Dipswitches (see tables above) All Output functions are programmed from the Elite-S, please see pg4 for programming assignment.

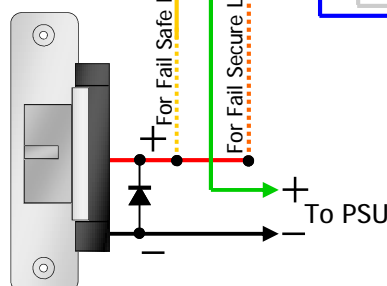

Garage Door Controller



### Normal Open Contacts

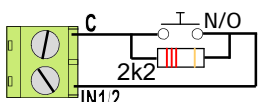

### Normal Closed Contacts

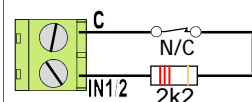

# Panel Connection & Power Supply Options:

## Powered from Elite-S

Maximum current available down 1 cable from the keypad bus is 200mA. So no locks can be driven from this power source and only 1 Keypad Interface should be used.

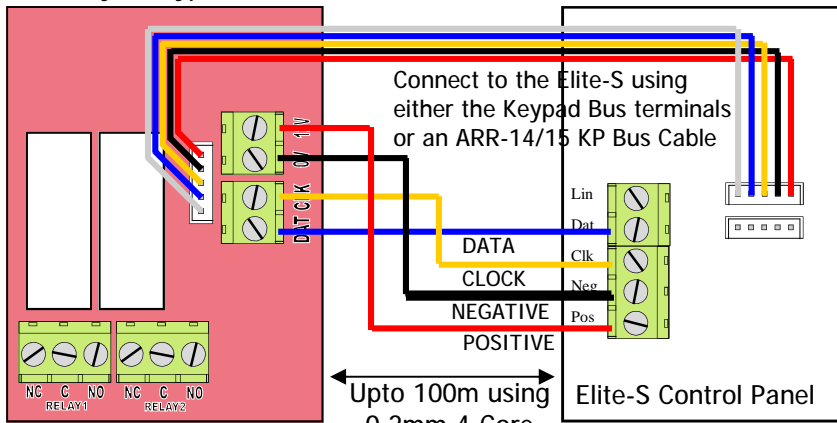

## Independent PSU

Output Voltage should be 12 to 13.8VDC, (Battery Back-up is recommended).

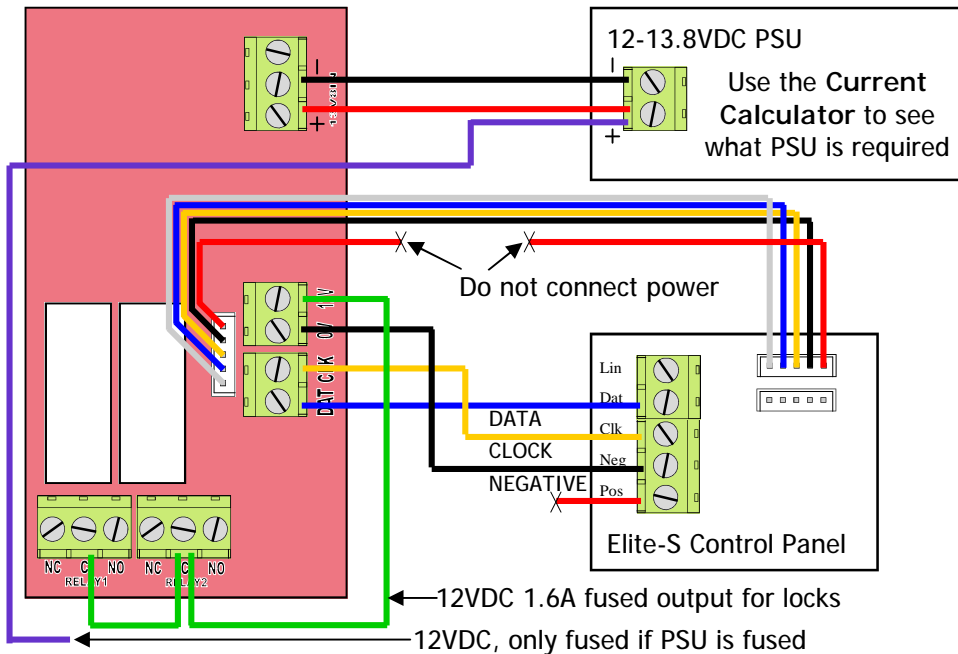

## iPSU Power Module

1.6Amp Plug-in Power Module with Battery Back-up

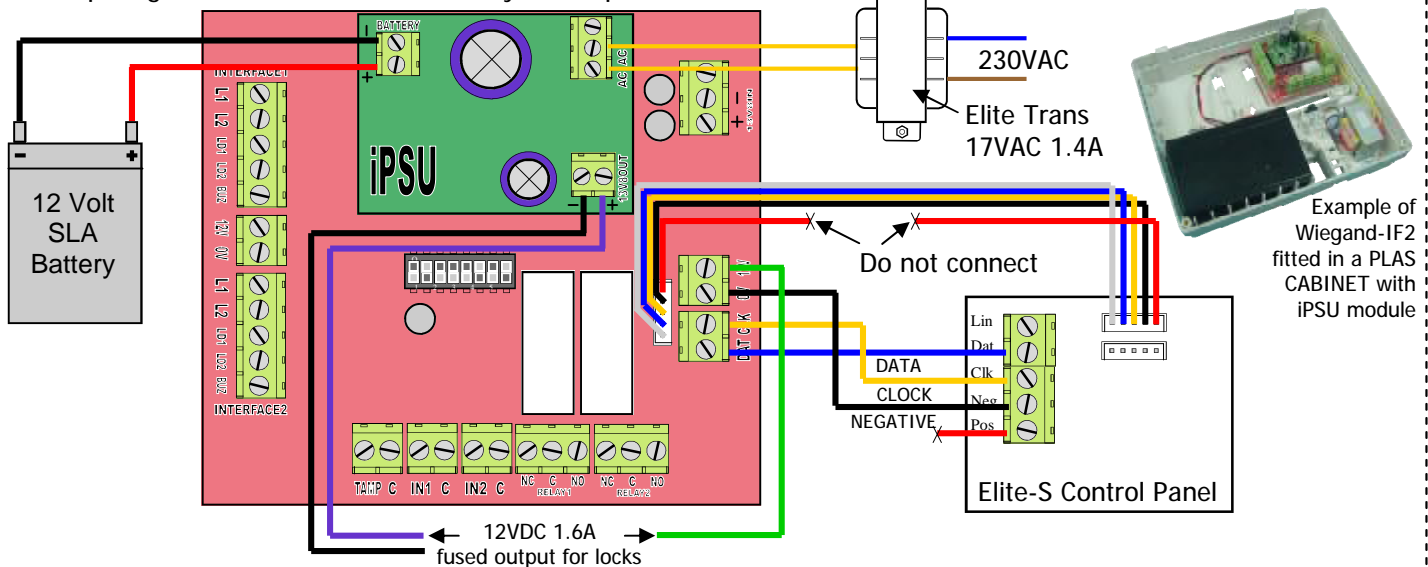

## Current Calculator

Device	Max. Current
Wiegand-IF2	100mA
Reader-1	
Reader-2	
Lock-1	
Lock-2	
REX	
Subtotal	
+30% overhead	
Total Required	

Current Draw Table	
Wiegand-IF2	100mA
Competition Reader	100mA
PW Wiegand	100mA
Strike Lock	250mA
Mag Lock	500mA
Door Hold	200mA
Drop Bolt	1000mA
Prox REX	50mA

Example	Current
Wiegand-IF2	100mA
Reader-1 = Competition	100mA
Reader-2 = PW Wiegand	100mA
Lock-1 = Mag Lock	500mA
Lock-2 = Strike Lock	250mA
REX = Prox REX	50mA
Subtotal	1100mA
+30% overhead	330mA
Total Required	1430mA

## Programming: (FOR ELITE S ONLY)

Please note that programming can not be done from the Wiegand keypads attached to the Wiegand-IF2. It can only be done from the standard alarm keypads.

### Keypad Mapping to Outputs

The Elite S can support up to 8 Keypads, each Keypad can be told to control any of the 8 outputs. By default outputs 1 & 2 are for Sirens, leaving outputs 3, 4, 5, 6, 7 & 8 free to be customized as you wish. To map a keypad to an output, you must be in Installer mode, then press <PROGRAM> <82> <ENTER> then the Keypad you wish to Map <1-8> then <ENTER>, now select the Output or Outputs that are to be controlled <1-8> then <ENTER>.

i.e. P 82 E 5 E 5 E (keypad 5 is now allowed to use output 5)

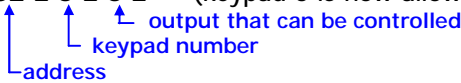

### User/Tag Mapping to Outputs

When setting up User to Output Control, you will need to map a User to an output. This is done under address 12, user slot 1-100, each user gets set up individually. To Map a user to an output, you must be in Installer mode, then press <PROGRAM> <12> <ENTER> then the user you wish to Map <1-100> then <ENTER>, now select the Output or Outputs that are to be controlled <1-8> then <ENTER>.

i.e. P 12 E 10 E 5 E (user 10 is now allowed to use output 5)  
P 12 E 11 E 5 6 E (user 11 is now allowed to use output 5 and 6)

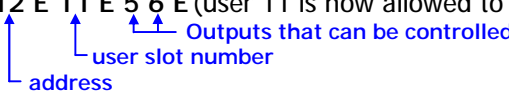

### User/Tag On Command to Outputs

Once users have been Mapped to an Output you then need to tell each user what they can do to that output. This is done under address 13, user slot 1-100, each user gets setup individually. To allow a user to turn On an Output, you must be in Installer mode then press <PROGRAM> <13> <ENTER> then a user you have Mapped <1-100> and <ENTER>, now select the Output/s that is to be controlled <1-8> and <ENTER>.

i.e. P 13 E 10 E 5 E (user 10 will now turn On Output 5)  
P 13 E 11 E 5 6 E (user 11 will now turn On Output 5 and 6)

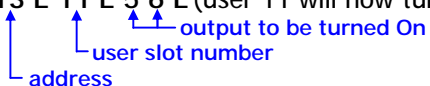

### Output Options

To complete the User to Output Control programming, you will need to tell the Output it is allowed to be controlled by Users. This is done at address 34. In Installer mode press <PROGRAM> <34> <ENTER> then choose the output <1-8> and <ENTER>, now turn ON option <6> and <ENTER>.

i.e. P 34 E 5 E 6 E (users are now allowed to control output 5).

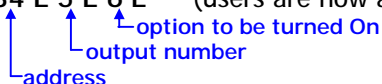

### Output Reset Times

This is how long the Output will switch on for, before turning off automatically. The Time is in seconds. In Installer Mode press <PROGRAM> <40> <ENTER> then the output you wish to change <1-8> and <ENTER> now put in the new reset time <0-9999> and <ENTER>.

i.e. P 40 E 5 E 10 E (output 5 will now automatically turn Off after 10 seconds).

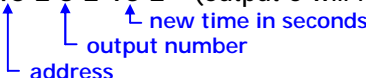

### Other Useful Addresses

P 1 E 1-100 E Adding User Codes (for adding, changing and deleting user codes) page 37  
P 4 E 1-100 E Changing User Access Options (can a user Arm/Disarm) page 38  
P 21 E 1-100 E Adding Prox Tags/Cards (enrol a prox device to a user slot) page 43  
P 2 E 1-100 E Changing User Type (user slot is a pin code, a prox device or both and/or) page 37  
P 71 E 1-8 E Keypad Area Assignment (if a keypad is not in an area it can't arm or disarm) page 57  
P 134 E 1-16 E Zone Alarm Beeps to Keypad (what keypad will beep when alarm activates) page 73

\*Page numbers refer to Full Elite S Manual

## Input Assignment

Once the Dipswitches have been set (see pg2) the desired zone needs to be set to be a Keypad Zone. This is done at address 122. In Installer mode press <PROGRAM> <122> <ENTER> then choose the zone <1-16> and <ENTER>, now turn ON option <4> and <ENTER>.

i.e. P 122 E 13 E 4 E (zone 13 now looks to the keypad bus for activity).

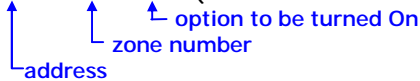

## Zone to Output Direct Control (REX Input)

If the zone is required to directly control an output, for use like a request to exit trigger, then the zone needs to be setup as a Chime Zone. This is done at address 123. In Installer mode press <PROGRAM> <123> <ENTER> then select the zone <1-16> and <ENTER>, now turn ON option <7> and <ENTER>.

i.e. P 123 E 13 E 7 E (zone 13 can directly control an output).

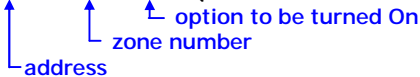

## Mapping Chime Zone to an Output

Once you have set a zone to be a chime zone, you will then need to link it to an output. This is done at address 131. In Installer mode press <PROGRAM> <131> <ENTER> then select the zone <1-16> and <ENTER>, now choose the output <1-8> and <ENTER>.

i.e. P 131 E 13 E 5 E (zone 13 can now be linked to output 5).

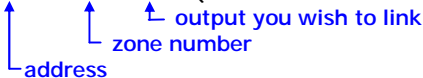

## Output Chime Reset Time

The direct control via chime zone feature, uses a separate reset timer to the normal output reset time. This timer is changed at address 41 and is set in 0.1second intervals. In Installer mode press <PROGRAM> <41> <ENTER> then select the output <1-8> and <ENTER>, now put in the new time <0-255> and <ENTER>.

i.e. P 41 E 5 E 100 E (output 5's chime reset time is now 10seconds).

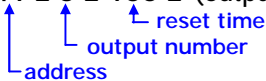

## LED 2 Assignment

You can program the second LED on both Interface 1 and 2 to follow an output. A good idea is to link it to the same Output that gets controlled by that keypad, so what the lock is released the LED turns on. In Installer mode press <PROGRAM> <98> <ENTER> then select the Keypad linked to the Interface <1-8> and <ENTER>.

Now choose an output/s for LED 2 to follow <1-8> and <ENTER>.

i.e. P 98 E 5 E 5 E (LED 2 on linked to Keypad 5 now follows Output 5).

P 98 E 6 E 6 E (LED 2 on linked to Keypad 6 now follows Output 6).

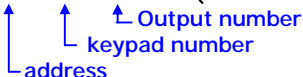

## PW WIEGAND SPECIAL BACKLIGHT FEATURE

The PW Wiegand device has the ability to automatically turn off its backlight after 20 seconds if no keys are pressed. (*feature not supported on CPT-DH16A models*)

To turn this feature Off press and hold the # key for 10 seconds. (the green led will flash to confirm)

To turn this feature On press and hold the # key for 10 seconds. (the green LED will flash 4 times)



ARROWHEAD ALARM PRODUCTS Ltd.  
344b Rosedale Rd,  
Albany,  
Auckland.  
Ph. 09 414 0085  
Fax. 09 414 0088  
[www.aap.co.nz](http://www.aap.co.nz)  
v1.02





# ELITE S ACCESS CONTROL WITH THE WIEGAND-IF2

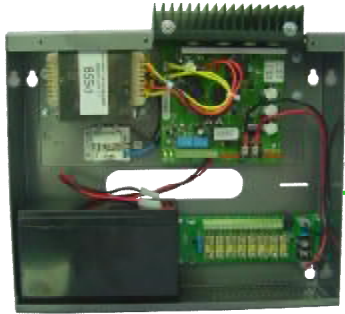

**PSU OPTION-1**  
PS5B  
BATTERY  
BACKUP

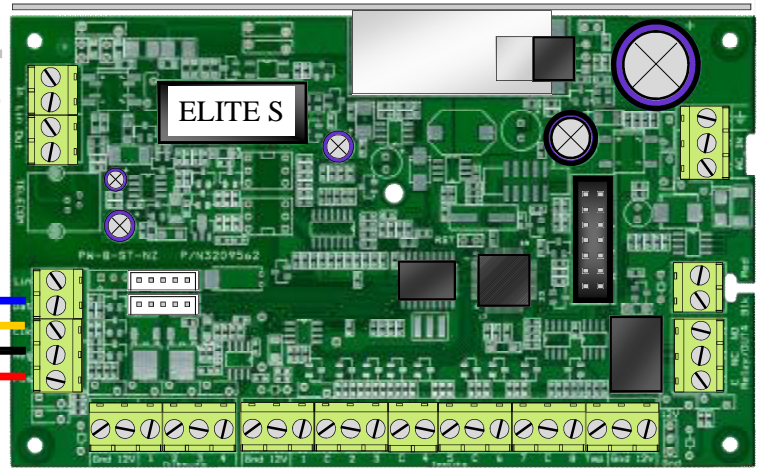

ELITE S

12VDC  
+  
-

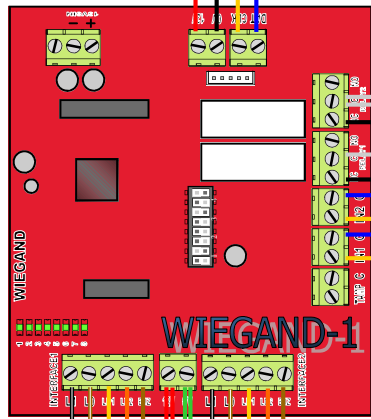

WIEGAND-1

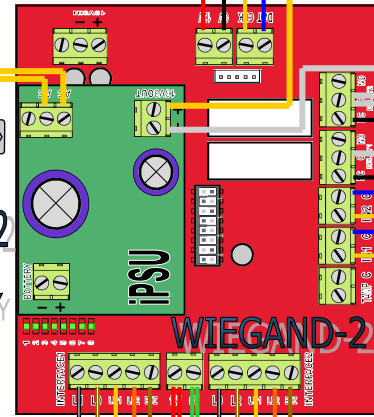

WIEGAND-2

**PSU OPTION-2**  
PLUG-IN PSU  
WITH BATTERY  
BACKUP

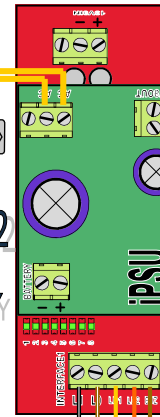

ACCESS  
KEYPAD-1



ACCESS  
KEYPAD-2



ACCESS  
KEYPAD-3



ACCESS  
KEYPAD-4

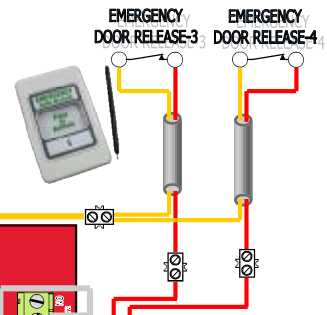
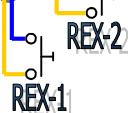
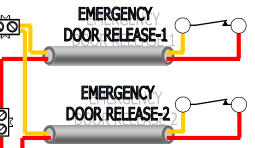

YM-500 (LED)  
800lb MAG LOCK  
INDOOR

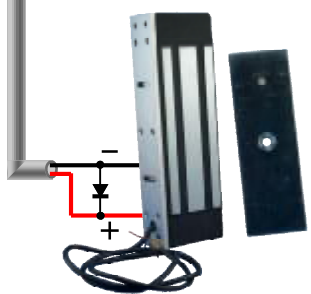

YM-500W  
800lb MAG LOCK  
S/S OUTDOOR

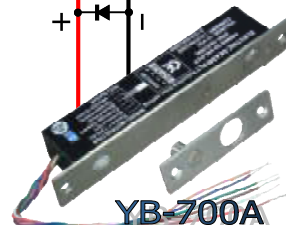

YB-700A  
DROP BOLT

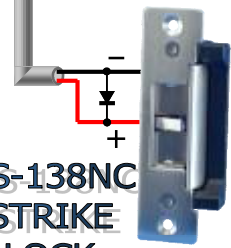

YS-138NC  
STRIKE  
LOCK